

Lecture 9: Critical Needs Supply Chains Under Disruptions

Professor Anna Nagurney

John F. Smith Memorial Professor
Director – Virtual Center for Supernetworks
Isenberg School of Management
University of Massachusetts
Amherst, Massachusetts 01003

SCH-MGMT 597LG
Humanitarian Logistics and Healthcare
Spring 2012
©Anna Nagurney 2012

Critical Needs Supply Chains Under Disruptions

This lecture is based on the paper by Professors Qiang "Patrick" Qiang and Anna Nagurney entitled, "A Bi-Criteria Indicator to Assess Supply Chain Network Performance for Critical Needs Under Capacity and Demand Disruptions," that appears in the Special Issue on Network Vulnerability in Large-Scale Transport Networks, *Transportation Research Part A* (2012), **46 (5)**, pp 801-812, where references may be found.

- ▶ Background and Research Motivation
- ▶ The Supply Chain Network Model for Critical Needs Under Disruptions
- ▶ Performance Measurement of Supply Chain Networks for Critical Needs
- ▶ Numerical Examples
- ▶ Conclusions

Background and Research Motivation

- ▶ From January to October 2005 alone, an estimated **97,490** people were killed in disasters globally; **88,117** of them lost their lives because of natural disasters (Braine 2006).
- ▶ Some of the deadliest examples of disasters that have been witnessed in the past few years:
 - ▶ September 11 attacks in 2001;
 - ▶ The tsunami in South Asia in 2004;
 - ▶ Hurricane Katrina in 2005;
 - ▶ Cyclone Nargis in 2008; and
 - ▶ The earthquakes in Sichuan, China in 2008.
 - ▶ The earthquakes in Japan in 2011.

Disruptions to Critical Needs Supply Chain Capacities and Uncertainties in Demands

- ▶ The winter storm in China in 2008 destroyed crop supplies – causing sharp food price inflation.
- ▶ Overestimation of the demand for certain products resulted in a surplus of supplies with around \$81 million of MREs being destroyed by FEMA.
- ▶ Of the approximately 1 million individuals evacuated after Katrina, about 100,000 suffered from diabetes, which requires daily medical supplies and caught the logistics chain completely off-guard.
- ▶ Thousands of lives could have been saved in the tsunami and other recent disasters if simple, cost-effective measures such as evacuation training and storage of food and medical supplies had been put into place.

Goals of Critical Needs Supply Chains

- ▶ The goals for humanitarian relief chains, for example, include cost reduction, capital reduction, and service improvement (cf. Beamon and Balcik (2008) and Altay and Green (2006)).
- ▶ “A successful humanitarian operation mitigates the urgent needs of a population with a sustainable reduction of their vulnerability in the shortest amount of time and with the least amount resources.” (Tomasini and Van Wassenhove (2004)).

Critical Needs Supply Chains

The model considers the following important factors:

- ▶ The supply chain capacities may be affected by disruptions;
- ▶ The demands may be affected by disruptions;
- ▶ Disruption scenarios are categorized into two types; and
- ▶ The organizations (NGOs, government, etc.) responsible for ensuring that the demand for the essential product be met are considering the possible supply chain activities, associated with the product, which are represented by a network.

The Supply Chain Network Topology

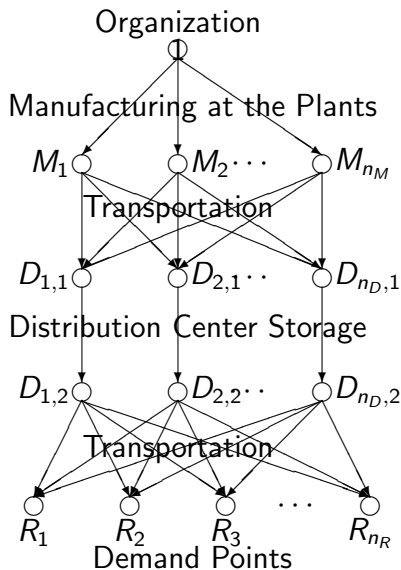

The Supply Chain Network Model for Critical Needs Under Disruptions: Case I: Demands Can Be Satisfied Under Disruptions

We are referring, in this case, to the disruption scenario set Ξ^1 .

$$v_k^{\xi_i^1} \equiv \sum_{p \in P_{w_k}} x_p^{\xi_i^1}, \quad k = 1, \dots, n_R, \forall \xi_i^1 \in \Xi^1; i = 1, \dots, \omega^1, \quad (1)$$

where $v_k^{\xi_i^1}$ is the demand at demand point k under disruption scenario ξ_i^1 ; $k = 1, \dots, n_R$ and $i = 1, \dots, \omega^1$.

Let $f_a^{\xi_i^1}$ denote the flow of the product on link a under disruption scenario ξ_i^1 . Hence, we must have the following conservation of flow equations satisfied:

$$f_a^{\xi_i^1} = \sum_{p \in P} x_p^{\xi_i^1} \delta_{ap}, \quad \forall a \in L, \forall \xi_i^1 \in \Xi^1; i = 1, \dots, \omega^1. \quad (2)$$

Case I: Demands Can Be Satisfied Under Disruptions

The total cost on a link, be it a manufacturing/production link, a transportation link, or a storage link is assumed to be a function of the flow of the product on the link We have that

$$\hat{c}_a = \hat{c}_a(f_a^{\xi_i^1}), \quad \forall a \in L, \forall \xi_i^1 \in \Xi^1; i = 1, \dots, \omega^1. \quad (3)$$

We further assume that the total cost on each link is convex and continuously differentiable. We denote the nonnegative capacity on a link a under disruption scenario ξ_i^1 by $u_a^{\xi_i^1}$, $\forall a \in L, \forall \xi_i^1 \in \Xi^1$, with $i = 1, \dots, \omega^1$.

Case I: Demands Can Be Satisfied Under Disruptions

The supply chain network optimization problem for critical needs faced by the organization can be expressed as follows: Under the disruption scenario ξ_i^1 , the organization must solve the following problem:

$$\text{Minimize } TC^{\xi_i^1} = \sum_{a \in L} \hat{c}_a(f_a^{\xi_i^1}) \quad (4)$$

subject to: constraints (1), (2) and

$$x_p^{\xi_i^1} \geq 0, \quad \forall p \in P, \forall \xi_i^1 \in \Xi^1; i = 1, \dots, \omega^1, \quad (5)$$

$$f_a^{\xi_i^1} \leq u_a^{\xi_i^1}, \quad \forall a \in L. \quad (6)$$

Case I: Demands Can Be Satisfied

Denote $K^{\xi_i^1}$ as the feasible set such that

$$K^{\xi_i^1} \equiv \{(x^{\xi_i^1}, \lambda^{\xi_i^1}) \mid x^{\xi_i^1} \text{ satisfies (1), } x^{\xi_i^1} \in R_+^{n_P} \text{ and } \lambda^{\xi_i^1} \in R_+^{n_L}\}.$$

Theorem 1 The optimization problem (4), subject to constraints (1), (2), (5), and (6), is equivalent to the variational inequality problem: determine the vector of optimal path flows and the vector of optimal Lagrange multipliers $(x^{\xi_i^1*}, \lambda^{\xi_i^1*}) \in K^{\xi_i^1}$, such that:

$$\sum_{k=1}^{n_R} \sum_{p \in P_{W_k}} \left[\frac{\partial \hat{C}_p(x^{\xi_i^1*})}{\partial x_p} + \sum_{a \in L} \lambda_a^{\xi_i^1*} \delta_{ap} \right] \times [x_p^{\xi_i^1} - x_p^{\xi_i^1*}] + \sum_{a \in L} [u_a^{\xi_i^1} - \sum_{p \in P} x_p^{\xi_i^1*} \delta_{ap}] \times [\lambda_a^{\xi_i^1} - \lambda_a^{\xi_i^1*}] \geq 0, \quad \forall (x^{\xi_i^1}, \lambda^{\xi_i^1}) \in K^{\xi_i^1}, \quad (7)$$

where $\frac{\partial \hat{C}_p(x^{\xi_i^1})}{\partial x_p} \equiv \sum_{a \in L} \frac{\partial \hat{c}_a(f_a^{\xi_i^1})}{\partial f_a} \delta_{ap}$ for paths $p \in P_{W_k}; k = 1, \dots, n_R$.

The Supply Chain Network Model for Critical Needs Under Disruptions: Case II: Demands Cannot Be Satisfied Under Disruptions

The disruption scenario set in this case is Ξ^2 ; that is to say, the optimization problem (4) is not feasible anymore. A max-flow algorithm can be used to decide how much demand can be satisfied.

Performance Measurement of Supply Chain Networks for Critical Needs

Performance Indicator I: Demands Can Be Satisfied:

For disruption scenario ξ_i^1 , the corresponding network performance indicator is:

$$\mathcal{E}_1^{\xi_i^1}(G, \hat{c}, v^{\xi_i^1}) = \frac{TC^{\xi_i^1} - TC^0}{TC^0}, \quad (8)$$

where TC^0 is the minimum total cost obtained as the solution to the cost minimization problem (4).

Performance Measurement of Supply Chain Networks for Critical Needs

Performance Indicator II: Demands Cannot Be Satisfied:

For disruption scenario ξ_i^2 , the corresponding network performance indicator is:

$$\mathcal{E}_2^{\xi_i^2}(G, \hat{c}, v^{\xi_i^2}) = \frac{TD^{\xi_i^2} - TSD^{\xi_i^2}}{TD^{\xi_i^2}}, \quad (9)$$

where $TSD^{\xi_i^2}$ is the total satisfied demand and $TD^{\xi_i^2}$ is the total (actual) demand under disruption scenario ξ_i^2 .

Definition: Bi-Criteria Performance Indicator for a Supply Chain Network for Critical Needs

The performance indicator, \mathcal{E} , of a supply chain network for critical needs under disruption scenario sets Ξ^1 and Ξ^2 and with associated probabilities $p_{\xi_1^1}, p_{\xi_2^1}, \dots, p_{\xi_{\omega^1}^1}$ and $p_{\xi_1^2}, p_{\xi_2^2}, \dots, p_{\xi_{\omega^2}^2}$, respectively, is defined as:

$$\mathcal{E} = \epsilon \times \left(\sum_{i=1}^{\omega^1} \mathcal{E}_1^{\xi_i^1} p_{\xi_i^1} \right) + (1 - \epsilon) \times \left(\sum_{i=1}^{\omega^2} \mathcal{E}_2^{\xi_i^2} p_{\xi_i^2} \right) \quad (10)$$

where ϵ is the weight associated with the network indicator when demands can be satisfied, which has a value between 0 and 1. The higher ϵ is, the more emphasis is put on the cost efficiency.

Modified Projection Method (cf. Korpelevich (1977) and Nagurney (1993))

Step 0: Initialization

Set $X^{\xi_i^1 0} \in K^{\xi_i^1}$. Let $\mathcal{T} = 1$ and set α such that $0 < \alpha \leq \frac{1}{L}$ where L is the Lipschitz constant for the problem.

Step 1: Computation

Compute $\bar{X}^{\xi_i^1 \mathcal{T}}$ by solving the variational inequality subproblem:

$$\langle (\bar{X}^{\xi_i^1 \mathcal{T}} + \alpha F(X^{\xi_i^1 \mathcal{T}-1}) - X^{\xi_i^1 \mathcal{T}-1})^T, X^{\xi_i^1} - \bar{X}^{\xi_i^1 \mathcal{T}} \rangle, \forall X^{\xi_i^1} \in K^{\xi_i^1}. \quad (11)$$

Step 2: Adaptation

Compute $X^{\xi_i^1 \mathcal{T}}$ by solving the variational inequality subproblem:

$$\langle (X^{\xi_i^1 \mathcal{T}} + \alpha F(\bar{X}^{\xi_i^1 \mathcal{T}-1}) - \bar{X}^{\xi_i^1 \mathcal{T}-1})^T, X^{\xi_i^1} - X^{\xi_i^1 \mathcal{T}} \rangle, \forall X^{\xi_i^1} \in K^{\xi_i^1}. \quad (12)$$

Modified Projection Method (cf. Korpelevich (1977) and Nagurney (1993))

Step 3: Convergence Verification

If $\max |X_l^{\xi_i^{1^{\mathcal{T}}}} - X_l^{\xi_i^{1^{\mathcal{T}-1}}}| \leq e$, for all l , with $e > 0$, a prespecified tolerance, then stop; else, set $\mathcal{T} = \mathcal{T} + 1$, and return to Step 1.

Numerical Examples – The Supply Chain Topology

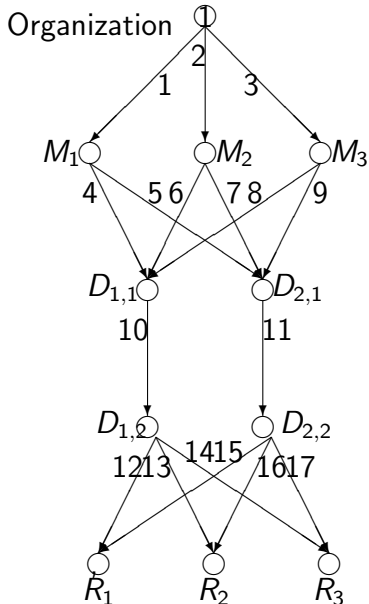

Total Cost Functions, Capacities, and Solution for the Baseline Numerical Example Under No Disruptions

Link a	$\hat{c}_a(f_a)$	u_a^0	f_a^{0*}	λ_a^{0*}
1	$f_1^2 + 2f_1$	10.00	3.12	0.00
2	$.5f_2^2 + f_2$	10.00	6.88	0.00
3	$.5f_3^2 + f_3$	5.00	5.00	0.93
4	$1.5f_4^2 + 2f_4$	6.00	1.79	0.00
5	$f_5^2 + 3f_5$	4.00	1.33	0.00
6	$f_6^2 + 2f_6$	4.00	2.88	0.00
7	$.5f_7^2 + 2f_7$	4.00	4.00	0.05
8	$.5f_8^2 + 2f_8$	4.00	4.00	2.70
9	$f_9^2 + 5f_9$	4.00	1.00	0.00
10	$.5f_{10}^2 + 2f_{10}$	16.00	8.67	0.00
11	$f_{11}^2 + f_{11}$	10.00	6.33	0.00
12	$.5f_{12}^2 + 2f_{12}$	2.00	3.76	0.00
13	$.5f_{13}^2 + 5f_{13}$	4.00	2.14	0.00
14	f_{14}^2	4.00	2.76	0.10
15	$f_{15}^2 + 2f_{15}$	2.00	1.24	0.00
16	$.5f_{16}^2 + 3f_{16}$	4.00	2.86	0.00
17	$.5f_{17}^2 + 2f_{17}$	4.00	2.24	0.00

There Are Three Disruption Scenarios – Numerical Example Set I

- 1 The capacities on the manufacturing links 1 and 2 are disrupted by 50% and the demands remain unchanged. (Disruption type 1)
- 2 The capacities on the storage links 10 and 11 are disrupted by 20% and the demands at the demand points 1 and 2 are increased by 20%. (Disruption type 1)
- 3 The capacities on links 12 and 15 are decreased by 50% and the demand at demand point 1 is increased by 100%. The probabilities associated with these three scenarios are: 0.4, 0.3, 0.2, respectively, and the probability of no disruption is 0.1. (Disruption type 2)

For 1 and 2, we have: $TC^{\xi_1^1} = 299.02$ and $TC^{\xi_2^1} = 361.41$;

therefore, $\mathcal{E}_1^{\xi_1^1} = \frac{TC^{\xi_1^1} - TC^0}{TC^0} = 0.0296$, $\mathcal{E}_1^{\xi_2^1} = \frac{TC^{\xi_2^1} - TC^0}{TC^0} = 0.2444$. 

There Are Three Disruption Scenarios – Example Set I

For 3, we have that $\mathcal{E}_1^{\xi_2^2} = \frac{TD^{\xi_1^2} - TSD^{\xi_1^2}}{TD^{\xi_1^2}} = 0.7000$.

We let $\epsilon = 0.2$ to reflect the importance of being able to satisfy demands and we compute the bi-criteria supply chain performance indicator as:

$$\mathcal{E} = 0.2 \times (0.4 \times \mathcal{E}_1^{\xi_1^1} + 0.3 \times \mathcal{E}_1^{\xi_2^1}) + 0.8 \times (0.2 \times \mathcal{E}_2^{\xi_1^2}) = 0.1290.$$

Numerical Example Set II

Everything is the same as in Example Set 1 above except that under the third scenario above, the disruptions have decreased the demand by 20% at demand point 1 but have increased the demand by 20% at demand point 2.

Numerical Example Set II

It is reasonable to assume that the critical needs demands may move from one point to another under disruptions and it is important for a supply chain to be able to meet the demands in such scenarios. Indeed, those affected may need to be evacuated to other locations, thereby, altering the associated demands. Under this scenario, we know that all the demands can be satisfied and we have that $TC^{\xi_3^1} = 295.00$, which means that $\mathcal{E}^{\xi_3^1} = \frac{TC^{\xi_3^1} - TC^0}{TC^0} = 0.0157$. Hence, given the same weight ϵ as in the First Case, the bi-criteria supply chain performance indicator is now:

$$\mathcal{E} = 0.2 \times (0.4 \times \mathcal{E}_1^{\xi_1^1} + 0.3 \times \mathcal{E}_1^{\xi_2^1} + .2 \times \mathcal{E}_1^{\xi_3^1}) + 0.8 \times (0.2 \times \mathcal{E}_2^{\xi_1^2}) = 0.0177.$$

Conclusions

- ▶ We developed a supply chain network model for critical needs, which captures disruptions in capacities associated with the various supply chain activities of production, transportation, and storage, as well as those associated with the demands for the product at the various demand points.
- ▶ We showed that the governing optimality conditions can be formulated as a variational inequality problem with nice features for numerical solution.
- ▶ We proposed two distinct supply chain network performance indicators for critical needs products. We then constructed a bi-criteria supply chain network performance indicator and used it for the evaluation of distinct supply chain networks. The bi-criteria performance indicator allows for the comparison of the robustness of different supply chain networks under a spectrum of real-world scenarios.